



EBW® SERIES SPILL CONTAINERS

EBW® Series spill containers provide an economical solution for the collection of spilled product during normal tank filling of underground storage tanks. They are available in both grade level and below grade level models to meet the needs of your application and preference. The complete lineup of EBW® Series spill containers provides a basic, easy-to-install, and simple-to-maintain spill containment solution.

HIGHLIGHTS

- Available in both grade level and below grade level models to meet the needs of your application and preference.
- Single wall containment protection.
- The flexible polyethylene container is designed to move with natural ground movements.
- Drain and pump options facilitate easy return of spilled fuel back into the tank.
- A cast iron base provides stability (NPT or BSPT).
- Threaded base for new installations.
- Slip-on grade level models for retrofit applications use a gasket flanged bolt system to secure the spill container to the riser pipe and are designed to eliminate the need to remove the riser pipe from the tank when installing.
- Covers available in a variety of colors to clearly identify product contained in the tank and prevent cross drops.

Grade Level Spill Containers

- 5 gallon capacity.
- Grade level spill containers feature a durable cast iron deflector ring which provides protection from heavy traffic and truck plows while diverting water away from the spill container top.
- The container is equipped with a gravel guard to prevent backfill material from filling in around the movable shell, mitigating issues with ground movement.
- Composite, cast iron, or aluminum cover options.

Below Grade Spill Containers

- 5 gallon and 15 gallon capacity options.
- Below grade level spill containers feature a hinged, locking, watertight cover that prevents water from entering the containment.
- They include an 18" wide, 8" deep cast iron manway with either a composite or steel lid that allows forecourt traffic to pass cleanly over its top.

SPECIFICATIONS

Components

- | | |
|-------------------------------|------------------------|
| 1 Cover | 6 Gravel guard |
| 2 Cast iron deflector ring | 7 Concrete anchors |
| 3 Flexible polyethylene shell | 8 Locking cover |
| 4 Cast iron threaded base | 9 18" Cast iron manway |
| 5 Cast iron slip-on base | |

Grade Level

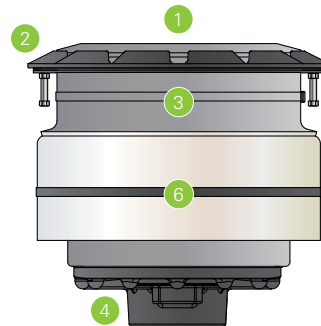

Grade Level Retrofit

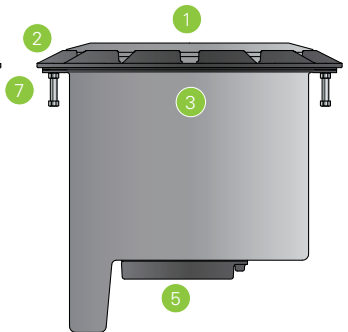

Below Grade

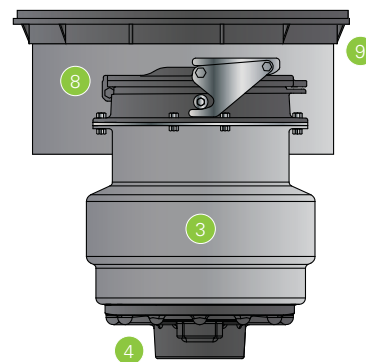

SPECIFICATIONS CONTINUED

Grade Level Spill Container Dimensions

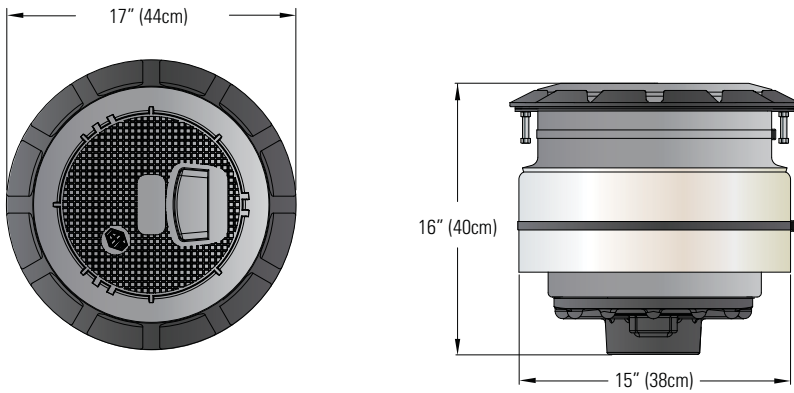

Grade Level Retrofit Spill Container Dimensions

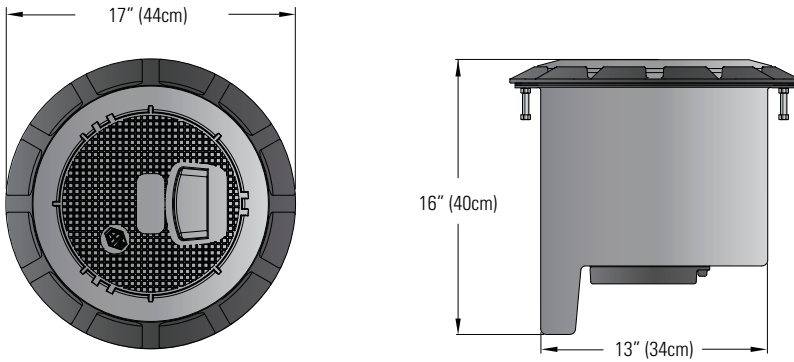

Below Grade Spill Container Dimensions

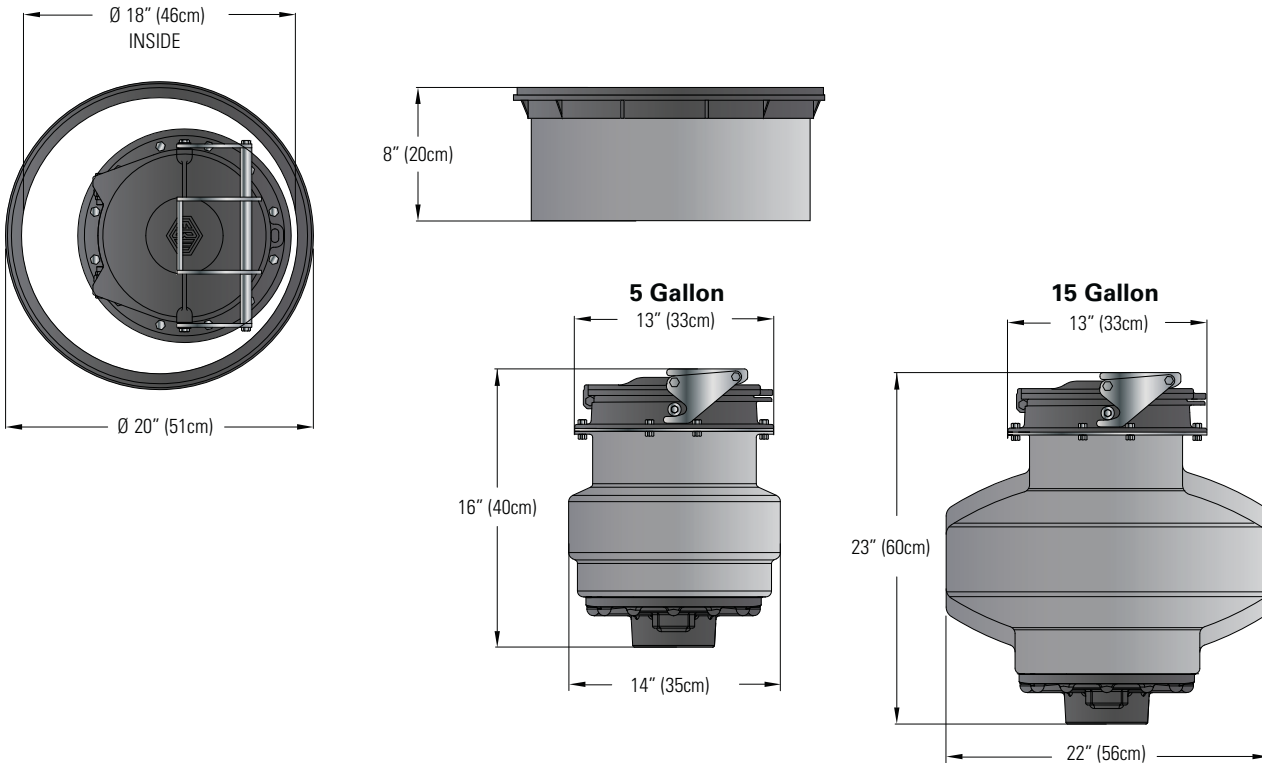

SPECIFICATIONS CONTINUED

Grade Level Spill Container Materials

- Base: Cast iron
- Container: Polyethylene
- Deflector ring: Cast iron
- Cover: Fiber reinforced composite (FRC), cast iron, or aluminum

Approvals/Certifications

- Spill containers and manways exceed DOT H20 requirements.
- ULC listed, MH21091*
- CARB Phase 1 EVR approved, VR-101*

*See ordering information for a listing of specific spill container models that hold this approval/certification.

UL2447 listed (below grade only)

Below Grade Spill Container Materials

- Base: Cast iron
- Container: Polyethylene
- Deflector ring: Cast iron
- Cover: Fiber reinforced composite (FRC), or steel

ORDERING INFORMATION

EBW® Series Grade Level Spill Containers

Model	Description
70547001ALUM	Grade level spill container, 5 gallon capacity, with drain, NPT threads, aluminum cover
70545801ALUM	Grade level spill container, 5 gallon capacity, without drain, NPT threads, aluminum cover
70547021ALUM	Grade level spill container, 5 gallon capacity, with drain, BSPT threads, aluminum cover
70547001BLK	Grade level spill container, 5 gallon capacity, with drain, NPT threads, black composite cover
70545801BLK	Grade level spill container, 5 gallon capacity, without drain, NPT threads, black composite cover
70547021BLK	Grade level spill container, 5 gallon capacity, with drain, BSPT threads, black composite cover
70545801CI-GKT*	Grade level spill container, 5 gallon capacity, with drain, NPT threads, cast iron cover with gasket
70547902CI-GKT*	Grade level spill container, 5 gallon capacity, without drain, NPT threads, cast iron cover with gasket
70549001BLK**	Grade level spill container, 5 gallon capacity, with drain, NPT threads, black composite cover (CARB approved)
70549002BLK**	Grade level spill container, 5 gallon capacity, without drain, NPT threads, black composite cover (CARB approved)

*ULC listed, MH21091

**CARB Phase 1 EVR approved, VR-101



EBW® Series Slide-On Grade Level Spill Containers

Model	Description
70240001BLK	Grade level spill container, 5 gallon capacity, with pump, slide-on base, black composite cover
70240601BLK	Grade level spill container, 5 gallon capacity, without pump, slide-on base, black composite cover
70240402CI-GKT*	Grade level spill container, 5 gallon capacity, without pump, slide-on base, cast iron cover with gasket

*ULC listed, MH21091



EBW® Series Grade Level Spill Container Covers

Replace the last letters in any standard spill container part number for these cover options.

Model	Description
BLK	Black composite
WHT	White composite
RED	Red composite
YEL	Yellow composite
ORG	Orange composite
BRN	Bronze composite
WHT-X	White with black cross composite
RED-X	Red with white cross composite
ALUM	Aluminum
CI	Cast iron
CI-GKT	Cast iron with gasket

ORDERING INFORMATION CONTINUED

EBW® Series Below Grade Spill Containers

Model	Description
70547401BLK*	Below grade spill container, 5 gallon capacity, with drain, NPT threads, 18" x 8" manway with black composite cover
70547402BLK*	Below grade spill container, 5 gallon capacity, without drain, NPT threads, 18" x 8" manway with black composite cover
70549201BLK**	Below grade spill container, 5 gallon capacity, with drain, NPT threads, 18" x 8" manway with black composite cover (CARB approved)
70549202BLK**	Below grade spill container, 5 gallon capacity, without drain, NPT threads, 18" x 8" manway with black composite cover (CARB approved)
71547401BLK*	Below grade spill container, 15 gallon capacity, with drain, NPT threads, 18" x 8" manway with black composite cover
71547402BLK*	Below grade spill container, 15 gallon capacity, without drain, NPT threads, 18" x 8" manway with black composite cover
71549201BLK**	Below grade spill container, 15 gallon capacity, with drain, NPT threads, 18" x 8" manway with black composite cover (CARB approved)
71549202BLK**	Below grade spill container, 15 gallon capacity, without drain, NPT threads, 18" x 8" manway with black composite cover (CARB approved)



*ULC listed, MH21091

**CARB Phase 1 EVR approved, VR-101

EBW® Series Manway Covers

Replace the last letters in any standard spill container part number for these cover options.

Model	Description	Model	Description
BLK	Black composite	YEL	Yellow composite
WHT	White composite	ORG	Orange composite
RED	Red composite	STL	Steel

EBW® Series Spill Container Replacement Parts

#	Model	Description
1	70542301	Cover, composite (black)
2	70544011	Cover, cast iron w/gasket (black)
3	77720102	Top seal fill cap
4	SWF-100-SS	Fill swivel adapter
5	70521307	4" x 3" close nipple
6	30430103	Top seal vapor cap
7	SWV-101-SS	Vapor swivel adapter
8	70541202	Fill riser, cap, and adapter kit for grade level spill containers
9	70541302	Vapor riser, cap, and adapter kit for grade level spill containers
10	70533219*	Pull-to-push drain valve kit
11	78130401	Cover, 18", fiberglass (black)
12	71040114 71040201	Lock down cover w/ base Lock down cover w/o base
13	70521305	4" x 5" close nipple
14	70541201	Fill riser, cap, and adapter kit for below grade spill containers
15	70541301	Vapor riser, cap, and adapter kit for below grade spill containers

*CARB approved model (P/N 70533719) also available.

Grade Level

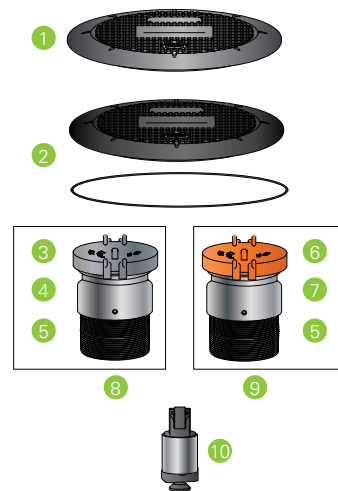

Below Grade

